

MB-7D PC

*FOR PROPRIETARY MB-7D LENGTHS, REFER TO MANUFACTURER

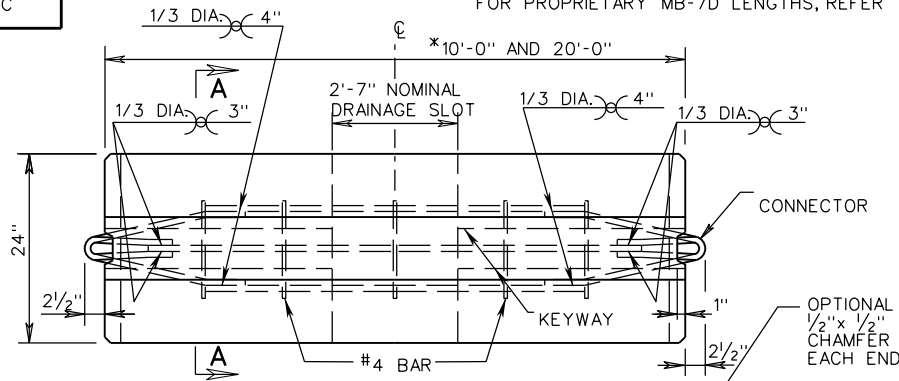

PLAN VIEW

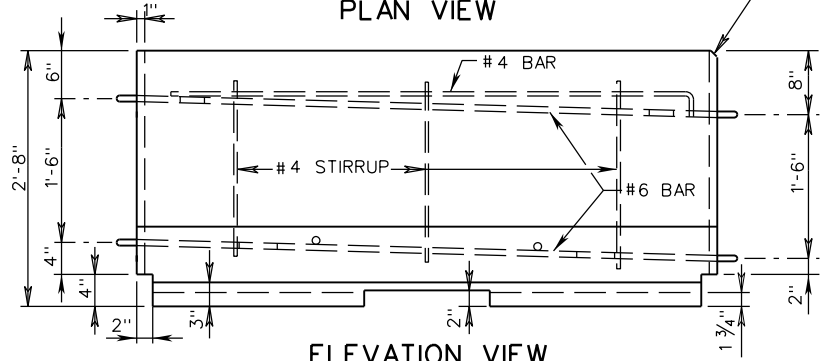

ELEVATION VIEW

NOTES:

1. FOR POSITIVE CONNECTION DETAILS AND DIMENSIONS SEE SHEETS 502.23 - 502.24.
2. AT THE OPTION OF THE MANUFACTURER, ADDITIONAL REINFORCING MAY BE ADDED TO THE PRECAST CONCRETE BARRIER FOR HANDLING.
3. CONCRETE SHALL BE 4000 P.S.I. MINIMUM.
4. BARRIER DELINEATOR SIZE, COLOR AND SPACING SHALL BE IN ACCORDANCE WITH THE SPECIFICATIONS.
5. COST OF DELINEATOR SHALL BE INCLUDED IN THE PRICE BID FOR TRAFFIC BARRIER SERVICE.
6. OTHER PRECAST TRAFFIC BARRIER SERVICE CONCRETE DESIGNS THAT HAVE BEEN APPROVED BY VDOT AS AN ACCEPTABLE ALTERNATE TO THE STANDARD DESIGN MAY BE SUBSTITUTED.
7. A 1" RADIUS MAY BE USED AS AN ALTERNATE FOR THE 3/4" CHAMFER.
8. BARRIER DELINEATOR REFLECTIVE SURFACE IN ALL INSTANCES SHALL BE FACING ONCOMING TRAFFIC.
9. BARRIER VERTICAL PANELS SHALL BE SPACED IN ACCORDANCE WITH VIRGINIA WORK AREA PROTECTION MANUAL.

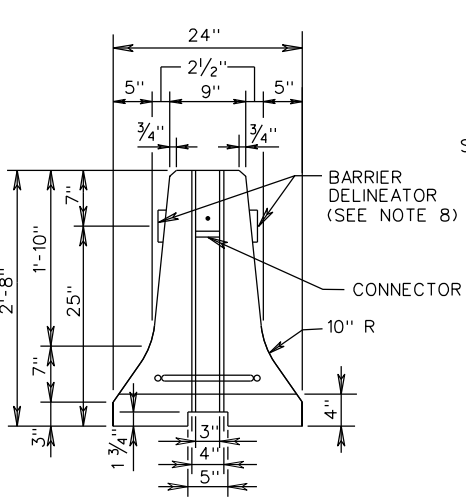

END VIEW

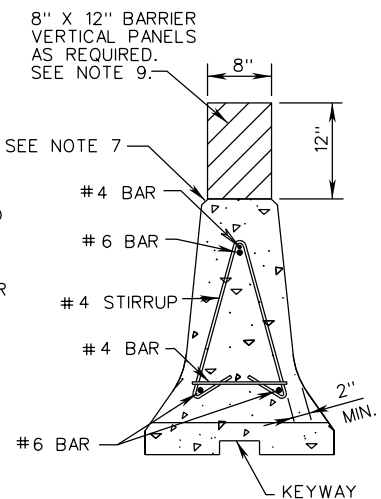

SECTION A-A

WHEN USING VDOT STANDARD MB-7D PC WITH THE PIN AND LOOP POSITIVE CONNECTION, ALLOW FOR A 6'-0" DYNAMIC DEFLECTION. PROVIDE MIN. 60' OF BARRIER UPSTREAM AND DOWNSTREAM OF WORK ZONE FOR ANCHORAGE. FOR APPROVED NON-VDOT DESIGNS, REFER TO MANUFACTURER'S INSTALLATION INSTRUCTIONS FOR DEFLECTIONS AND ANCHORAGE.

DESIGN SPEED	* FLARE RATES		
	INSIDE SHY LINE	BEYOND SHY LINE	
MPH	SHY LINE LS	FLARE RATE	FLARE RATE
70	10'	30:1	20:1
60	8'	26:1	18:1
50	6.5'	21:1	14:1
40	5'	16:1	10:1
30	3.5	13:1	8:1

* SUGGESTED MAXIMUM FLARED RATE FOR RIGID BARRIER SYSTEMS.



ROAD AND BRIDGE STANDARDS

SHEET 1 OF 2

REVISION DATE

502.05

7/16

PRECAST TRAFFIC BARRIER SERVICE CONCRETE

(FOR TEMPORARY USE)

VIRGINIA DEPARTMENT OF TRANSPORTATION

SPECIFICATION REFERENCE

105
512