

PIPE SPILLOUT
PLAN VIEW

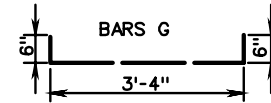

- * 12" PIPE - 3 BARS - 10.68 LBS. REINFORCING STEEL
- 15" PIPE - 2 BARS - 7.79 LBS. REINFORCING STEEL
- 18" PIPE - 2 BARS - 7.79 LBS. REINFORCING STEEL

SCHEDULE OF REINFORCING STEEL						
MARK	NO.	LENGTH		SIZE	SPACING C-C	SHAPE
		2:1	1/2:1			
F	5	1'-0"	1'-0"	4	4"	STRAIGHT
G	*	4'-4"	4'-4"	4	4"	BENT
L	12	2'-0"		3	12"	BENT
L	10		2'-0"	3	12"	BENT

‡ QUANTITIES BASED
ON 18" PIPE.

APPROXIMATE QUANTITIES			
PIPE	SLOPE	CLASS A3 CONCRETE	REINFORCING STEEL
		CUBIC YARDS	LBS.
PIPE	2:1	‡ 0.482	*
SPILLOUT	1/2:1	‡ 0.440	*

NOTE:
DOWELS TO BE LOCATED AT ALL
REQUIRED JOINTS.

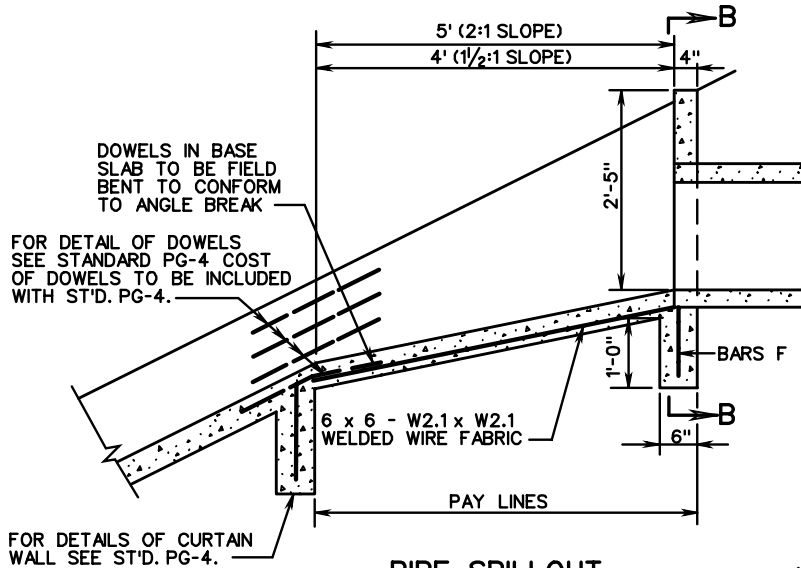

PIPE SPILLOUT
SECTION A-A

DOWELS IN BASE
SLAB TO BE FIELD
BENT TO CONFORM
TO ANGLE BREAK

FOR DETAIL OF DOWELS
SEE STANDARD PG-4 COST
OF DOWELS TO BE INCLUDED
WITH ST'D. PG-4.

FOR DETAILS OF CURTAIN
WALL SEE ST'D. PG-4.

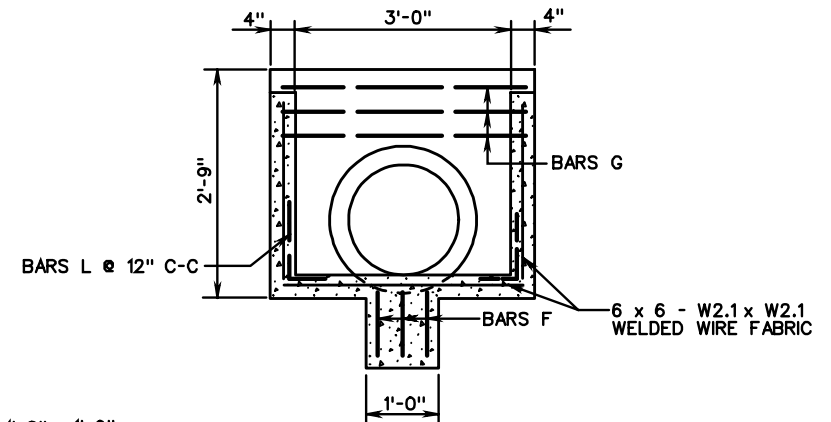

SECTION B-B

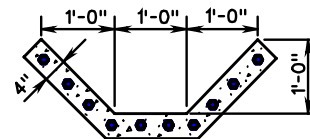

SECTION C-C

SPECIFICATION
REFERENCE

302

STANDARD PIPE SPILLOUT FOR 12" - 18" PIPE CULVERTS

VIRGINIA DEPARTMENT OF TRANSPORTATION

VDOT

ROAD AND BRIDGE STANDARDS

REVISION DATE

SHEET 1 OF 1

112.01