

DI-14D, 14E, 14F

NOTES

- VARIES GREATER THAN: 0' TO 18" MAX. TYPE I CHAMBER. 4" TO 3' MAX. TYPE I CHAMBER.
- FOR DETAILS AND DIMENSIONS NOT SHOWN FOR MEDIAN BARRIER, SEE STANDARD MB-13.
- GALVANIZED MC-6 X 12 IS TO BE WELDED UNDER THE COLLAR AND EXTENDED INTO SIDEWALLS TO WITHIN 2" OF OUTSIDE FACE.
- ALL REINFORCING BARS ARE TO BE GRADE 60 STEEL WITH MIN. OF 1 1/2" CONCRETE COVER. ANY BARS IN CONFLICT WITH PIPE SHELL AND/OR TOP SLAB OPENING ARE TO BE FIELD CUT TO PROVIDE THE REQUIRED COVER.
- DO NOT LOCATE STANDARD ST-1 STEPS ON CHAMBER WALLS THAT HAVE PIPES WHEN POSSIBLE.
- 8 DOWELS REQUIRED FOR DI-14F, MIN. L = 7'-0". ADD 2 DOWELS FOR EACH ADDITIONAL FOOT. 4 DOWELS REQUIRED FOR DI-14E, MIN. L = 4'-0". ADD 2 DOWELS FOR EACH ADDITIONAL FOOT.
- 12 BARS A REQUIRED FOR DI-14F.
- LENGTH OF BARS A, DI-14F = $\frac{L - (2' - 6")}{2}$
- DO NOT USE WITH DI-14D.
- USE 6 BARS F FOR DI-14F TYPE I.
- DO NOT USE WITH TYPE III
- ADD 4 ADDITIONAL BARS FOR EACH EXTRA FOOT OF DEPTH.
- USE 12 BARS F FOR DI-14F TYPE II
- 24 BARS A ARE REQUIRED FOR DI-14F.
- A MINIMUM 22" FOOTING DEPTH IS REQUIRED FOR FORMING THE INLET SLOT. SEE PLANS FOR LENGTH "L".
- REFER TO PLANS FOR STRUCTURE LOCATIONS, DATA AND DIMENSIONS.
- REFER TO PLANS FOR LOCATIONS OF PIPES AND INVERTS.
- FOR TYPE III, COST OF ACCOMMODATION OF INLET THROAT IS TO BE INCLUDED IN COST OF WALL BARRIER.
- FOR TYPE III, SEE WALL PLANS FOR WALL FOOTING DETAILS.
- 3" DIAMETER WEEP HOLE WITH 12"X12" PLASTIC HARDWARE CLOTH, 1/4" MESH OR GALV. STEEL WIRE, MIN. WIRE DIA. 0.03", NO. 4 MESH HARDWARE CLOTH ANCHORED FIRMLY TO THE OUTSIDE OF THE STRUCTURE.
- TYPE I DENOTES INLET WITH SINGLE THROAT AND CHAMBER. TYPE II DENOTES INLET WITH DOUBLE THROAT AND CHAMBER. TYPE III DENOTES INLET WITH SINGLE THROAT AND CHAMBER ADJACENT TO WALL OR BARRIER.
- MAXIMUM PIPE SIZE IS 24" DIAMETER.
- CONCRETE MEDIAN BARRIER (TALL WALL) SHALL HAVE DELINEATORS INSTALLED ON BARRIER WALL ORIENTED TOWARDS ONCOMING TRAFFIC AT APPROXIMATELY 25" ABOVE THE ROADWAY.
- PROVIDE SAFETY SLABS WHEN SPECIFIED ON THE PLANS.
- WHEN SPECIFIED ON THE PLANS, THE INVERT IS TO BE SHAPED IN ACCORDANCE WITH STANDARD IS-1. THE COST OF FURNISHING AND PLACING ALL MATERIALS INCIDENTAL TO THE SHAPING IS TO BE INCLUDED IN THE BID PRICE FOR THE STRUCTURE.

TYPE I & III INLET

REINFORCING STEEL

MARK	SIZE	NO.	LENGTH	SPACE
A SEE NOTE 9	#4	6	L - 2'-6" SEE NOTE 8	AS SHOWN
A-1 SEE NOTE 11	#4	(2XL)+2	5'-6"	12"
B SEE NOTE 9	#3	2X(L-4)	1'-1"	12"
B-1 SEE NOTE 11	#4	11	L + (2'-4")	8"
DOWELS	#4	SEE NOTE 6	1'-0"	6"
F SEE NOTE 9	#5	3	1'-6"	6"
H	#5	(4XH)+10	3'-2"	12"
H1	#5	(4XH)+8	2'-8"	10"

TYPE - II INLET

A-1	#4	(2XL)+2	5'-6"	12"
B-1	#4	11	L + (2'-4")	8"
H-2	#3	16 SEE NOTE 12	7'-8"	10"
V-1	#5	12	H - (1'-2")	8"
V-2	#4	30	LENGTH = H	8"
A SEE NOTE 15	#4	12 SEE NOTE 14	L - (2'-6") SEE NOTE 8	AS SHOWN
B SEE NOTE 15	#4	4(L-4)	1'-1"	12"
DOWELS	#3	DOUBLE NO. SHOWN FOR TYPE I	1'-0"	6"
F SEE NOTE 15	#5	6 SEE NOTE 13	1'-6"	6"
H	#5	(4 + H)+8	3'-2"	12"
H-1	#5	(4 + H)+16	2'-8"	10"
V	#4	30	LENGTH = H	8"
M-1	#5	5	3'-2"	5"
M	#4	4	1'-8"	12"

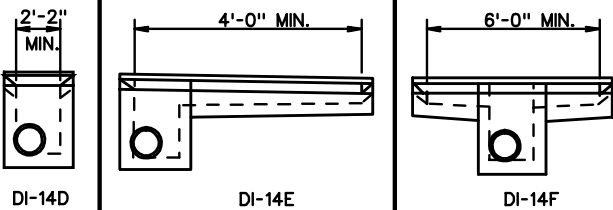
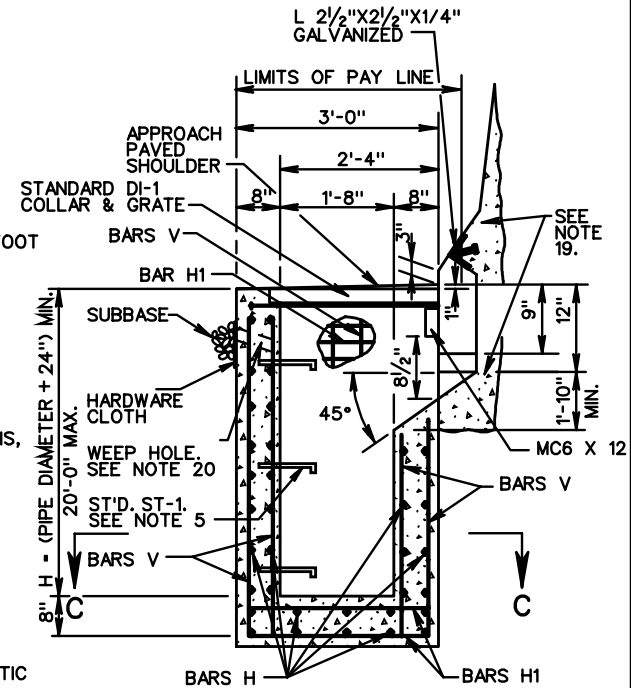

VDOT
ROAD AND BRIDGE STANDARDS
SHEET 2 OF 2
104.41

CONCRETE MEDIAN BARRIER DROP INLET
12"-24" PIPE: DEPTH (H)=20' MAX.
VIRGINIA DEPARTMENT OF TRANSPORTATION

SPECIFICATION REFERENCE
233
302