

TYPE A NOSE DETAIL SHALL BE USED WITH CG-3 & CG-7 STANDARDS.
 TYPE B NOSE DETAIL SHALL BE USED WITH CG-2 & CG-6 STANDARDS.
 GALVANIZED PLATE FOR TYPE A TO BE BENT ON AN ANGLE OF 68° 30' CONNECTORS AND IS TO BE ANCHORED WITH 1/2" X 4" STUD SHEAR WELDED TO BENT PLATE AT 2' C-C.

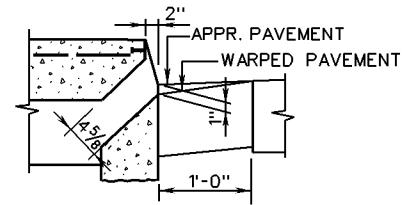
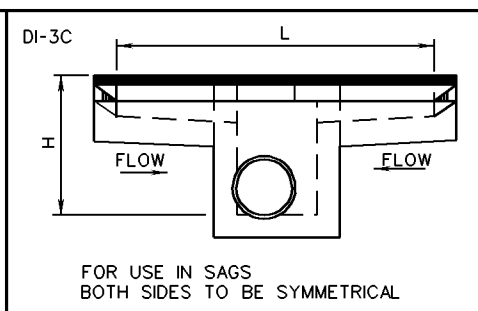
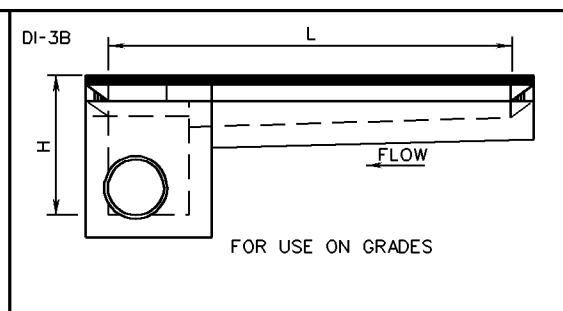
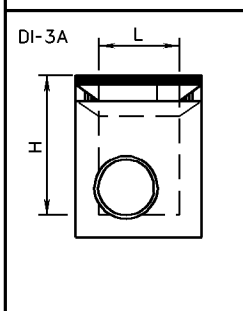

DETAIL WHEN USED ADJACENT TO CURB WITHOUT GUTTER

| | |
|-----------------------------------|---------------|
| VDOT ROAD AND BRIDGE STANDARDS | |
| SHEET 1 OF 2 | REVISION DATE |
| 104.09 | 08/10 |

STANDARD CURB DROP INLET
 12" - 30" PIPE: MAXIMUM DEPTH (H) - 8'
 VIRGINIA DEPARTMENT OF TRANSPORTATION

| |
|-------------------------|
| SPECIFICATION REFERENCE |
| 233 302 |