

PLAN VIEW

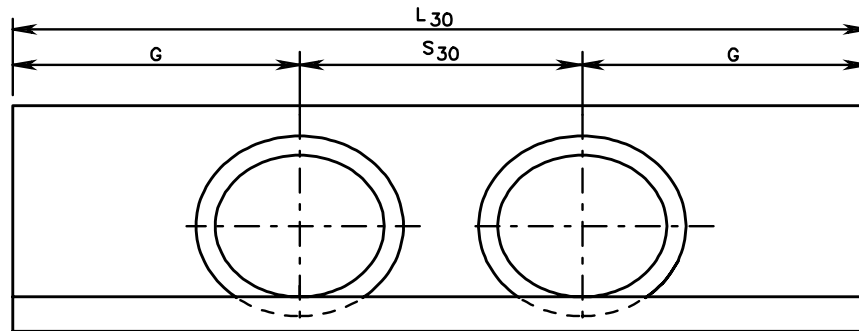

FRONT VIEW

NOTES:

1. QUANTITIES GIVEN ARE FOR ONE ENDWALL. PLEASE REFER TO STANDARD EW-1, SHEET 101.01 FOR ALL DIMENSIONS NOT GIVEN IN TABLES.
2. FOR DETAILS OF BEVEL SEE STANDARD EW-2, 2A, SHEET 101.03.
3. THIS ITEM MAY BE PRECAST OR CAST IN PLACE.
4. ON SHALLOW FILLS, WHERE ENDWALLS ARE 1' OR LESS BELOW SHOULDER LINE, THE TOP OF THE ENDWALL SHALL BE CONSTRUCTED PARALLEL TO THE GRADE OF ROAD.
5. ALL CAST IN PLACE CONCRETE TO BE CLASS A3. FOR PRECAST SEE SHEET 101.15.
6. IN NO CASE SHALL TOP OF ENDWALL PROJECT ABOVE FILL SLOPE, DITCH SLOPE, OR SHOULDER.
7. THIS STANDARD TO BE USED WITH SKEW ANGLES FROM 15° TO 37° 30'.
8. HEADWALL TO BE BEVELED IN ALL AREAS EXCEPT WHERE A CONFLICT WITH INVERT AND WINGWALLS OCCUR.
9. BEVEL EDGE IS REQUIRED ON THE HEADWALL AT THE INLET END OF THE CULVERT (WHERE THE FLOW ENTERS THE CULVERT). HEADWALL AT THE OUTLET END OF THE CULVERT MAY BE EITHER SQUARE EDGE OR BEVEL EDGE.
10. 3/4" CHAMFER MAY BE PROVIDED ON ALL EDGES AT MANUFACTURER'S OPTION.

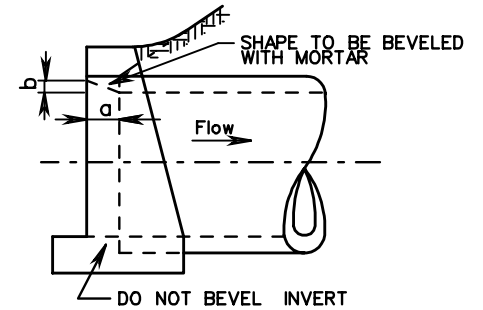

SIDE VIEW

FOR CONCRETE PIPE									
D	G	S	S ₃₀	L ₃₀	CONCRETE IN ONE DOUBLE ENDWALL CUBIC YDS.	INCREASE FOR EACH ADDITIONAL PIPE CUBIC YDS.	a	b	
12"	2'-0"	1'-10"	2'-13/8"	6'-13/8"	0.336	0.101	0'-1/4"	0'-1"	
15"	2'-6"	2'-3"	2'-7/8"	7'-7/8"	0.688	0.207	0'-1 3/4"	0'-1 1/4"	
18"	3'-0"	2'-8"	3'-1"	9'-1"	0.962	0.283	0'-2"	0'-1 1/2"	
21" OR 24"	4'-0"	3'-6"	4'-0 1/2"	12'-0 1/2"	1.794	0.512	0'-2 1/2"	0'-2"	
27" OR 30"	5'-0"	4'-4"	5'-0"	15'-0"	2.769	0.765	0'-3 1/4"	0'-2 1/2"	
33" OR 36"	6'-0"	5'-2"	5'-11 5/8"	17'-11 5/8"	3.895	1.048	0'-3 3/4"	0'-3"	

FOR CORRUGATED METAL PIPE									
D	G	S	S ₃₀	L ₃₀	CONCRETE IN ONE DOUBLE ENDWALL CUBIC YDS.	INCREASE FOR EACH ADDITIONAL PIPE CUBIC YDS.	a	b	
12"	2'-0"	1'-7"	1'-10"	5'-10"	0.354	0.100	0'-1 1/4"	0'-1"	
15"	2'-6"	1'-11 1/2"	2'-3 3/8"	7'-3 3/8"	0.714	0.201	0'-1 3/4"	0'-1 1/4"	
18"	3'-0"	2'-4"	2'-8 3/8"	8'-8 3/8"	1.005	0.278	0'-2"	0'-1 1/2"	
24"	4'-0"	3'-1"	3'-6 3/4"	11'-6 3/4"	1.882	0.510	0'-2 1/2"	0'-2"	
27" OR 30"	5'-0"	3'-10"	4'-5 5/8"	14'-5 5/8"	2.929	0.775	0'-3 1/4"	0'-2 1/2"	
36"	6'-0"	4'-7"	5'-3 1/2"	17'-3 1/2"	4.153	1.075	0'-3 3/4"	0'-3"	

SPECIFICATION REFERENCE

105
302

STANDARD ENDWALLS FOR MULTIPLE PIPE CULVERTS
12" - 36" CIRCULAR PIPES WITH 30° SKEW

VIRGINIA DEPARTMENT OF TRANSPORTATION

VDOT

ROAD AND BRIDGE STANDARDS

REVISION DATE

SHEET 1 OF 2

101.13